



The BENJAMIN ArcLight Track Light Limiter Panel™ Sub-Branch Circuit Current Limiter Panelboard



Helps meet Energy Code Regulations

The Benjamin ArcLight Track Light Limiter (ArcLight TLL) provides a mechanism to meet energy code mandates by limiting the current in Track Light applications by lowering the VA rating of each Track Light circuit.

Simplifies Load Calculations

The energy code calculations are based on the connected loads instead of the length of the lighting track. The Benjamin ArcLight TLL panel simplifies the calculated loads while maintaining compliance with state regulations.

Reduce Installation Costs

The Benjamin ArcLight TLL panel is a series-connected device that is interposed between the branch circuit breaker panel and the track lighting system.

New and Retrofit Applications

The Benjamin ArcLight TLL panel is used wherever showcase lighting is applied. Retail installations, grocery stores, and warehouse shopping centers are some examples of the countless locations where it is in use today.

Flexible Mounting Options

- Surface or flush wall mount
- Raintight Enclosures
- Current Limiting for up to 32 circuits
- Arrives ready to Install



The BENJAMIN ArcLight Track Light Limiter Panel™

Specifications

Voltage Ratings:	120V 1Ø 2W	277V 1Ø 2W						
AIC Ratings:	10kAIC @ 120V Fully Rated	6kAIC @ 277V Fully Rated						
Circuit Breaker Current Ratings (single pole):	0.5 Amp	1 Amp	2 Amp	3 Amp	4 Amp	5 Amp	6 Amp	7 Amp
	8 Amp	10 Amp	13 Amp	15 Amp	16 Amp	20 Amp	25 Amp	30 Amp
	32 Amp	40 Amp	50 Amp	60 Amp				
Certification:	Underwriters Laboratories Listed, UL508A							

Panel Dimensions

Flanged Trim Panel - up to 16 Circuits

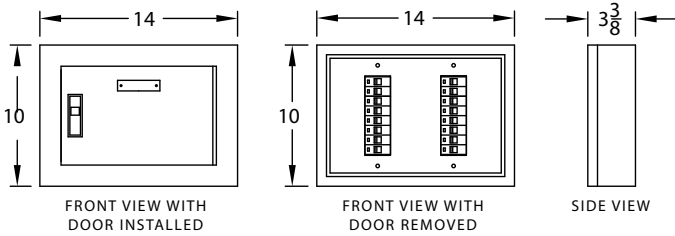

Flush Trim Panel - up to 16 Circuits

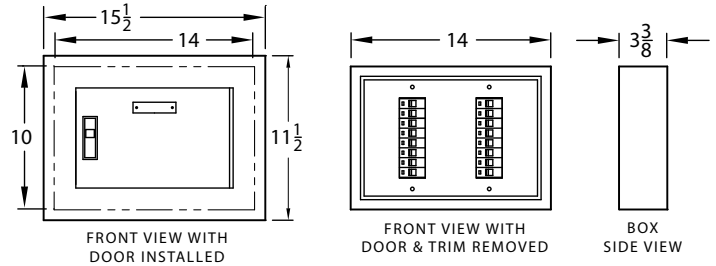

Flanged Trim Panel - up to 32 Circuits

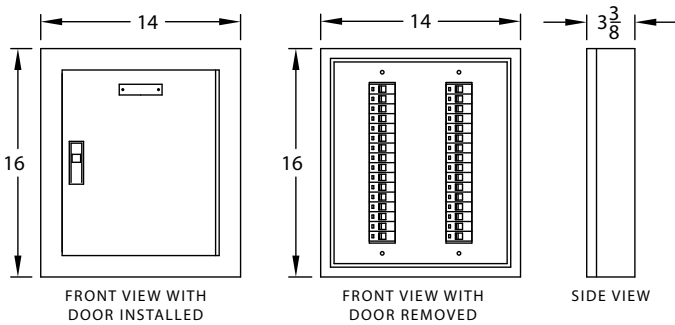

Flush Trim Panel - up to 32 Circuits

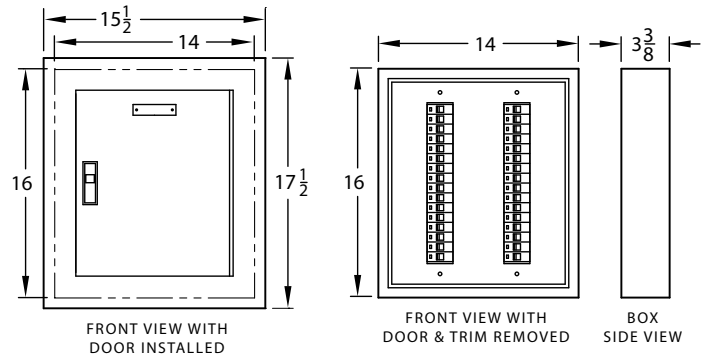

Typical Wiring Diagram

Benjamin ArcLight Panel (remote controllable circuit breakers)

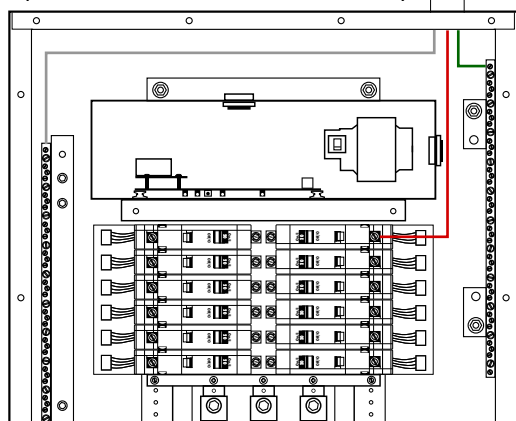

from controllable circuit breaker to single or multiple current limiting breakers

Benjamin TLL Panel (track light limiting circuits)

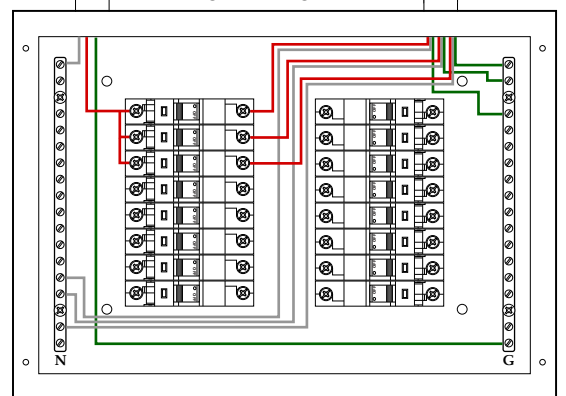

Manufacturers of Quality Electrical Power Distribution Equipment